

Handling System **HS flex hybrid**  
[www.hermle.de](http://www.hermle.de)

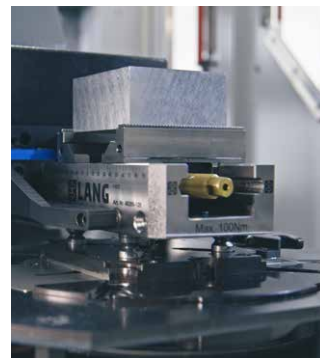

# HS FLEX HYBRID

The handling system HS flex hybrid is helping us take HS flex to the next level of production for the economic manufacture of components weighing up to 450 kg. The system transports both pallets and vises from the setup station to the storage modules or into the working area. The storage modules, setup station, gripper and adapter pallet have all been specially configured for the HS flex hybrid. Further, the HS flex hybrid can be adapted to six different machine models and configured with either one or two storage modules.

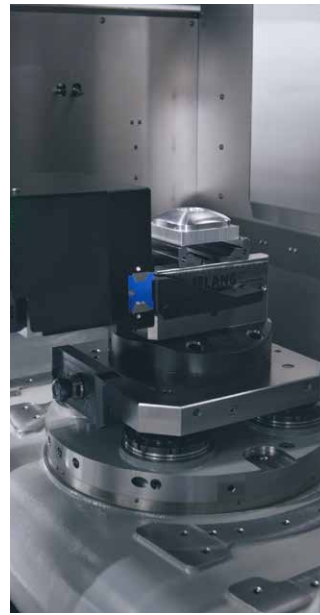

C 12 | C 22 | C 32 | C 42 | C 250 | C 400

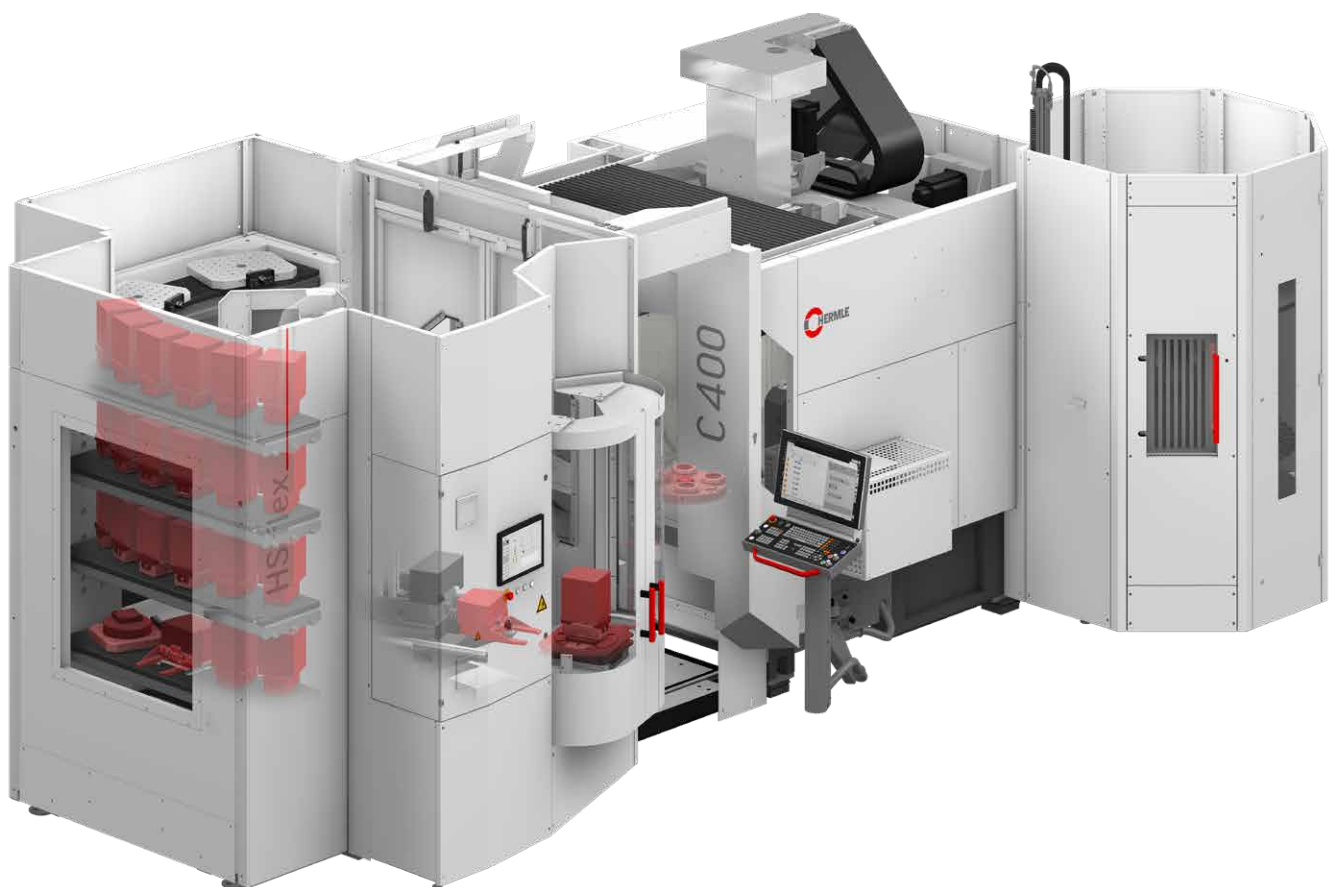

## *Advantages*

- MAX. FLEXIBILITY THROUGH THE USE OF PALLETS AND VISES
- UP TO FIVE TIMES MORE CAPACITY
- RETENTION OF THE POPULAR SETUP STRATEGY
- INTUITIVE OPERATION
- HACS - THE INTELLIGENT ORDER MANAGEMENT SYSTEM

## *Modifications*

- TABLE MODIFICATION WITH MEDIA TRANSFER
- LOCKABLE SETUP STATION
- EXCHANGEABLE GRIPPER FOR BASE PLATES AND SMALL / LARGE VISES
- SPECIAL STORAGE MODULE FOR EVEN MORE STORAGE

# DETAILS

## C 250

52 stud pitch – Preferred configuration 1 Storage Module



\*optionally also possible with two storage modules

## C 400

96 stud pitch – Preferred configuration 2 Storage Module



### Storage Module

- 3X PALLETS (UP TO 300KG / 661.3LBS)  
400 X 400MM / 15.7 X 15.7IN
- 30X □ 52 VISES (UP TO 30KG / 66LBS)
- 1X ADAPTER PALLET AND GRIPPER FOR VISES

### Storage Module

- 2X PALLETS (UP TO 450KG / 992LBS)  
500 X 400MM / 19.6 X 15.7IN
- 6X PALLETS (UP TO 450KG / 992LBS)  
400 X 400MM / 15.7 X 15.7IN
- 20X □ 96 VISES (UP TO 50KG / 110LBS)
- 1X ADAPTER PALLET AND GRIPPER FOR VISES

Clamping Interface 2



Clamping Interface 1

Clamping Interface 2

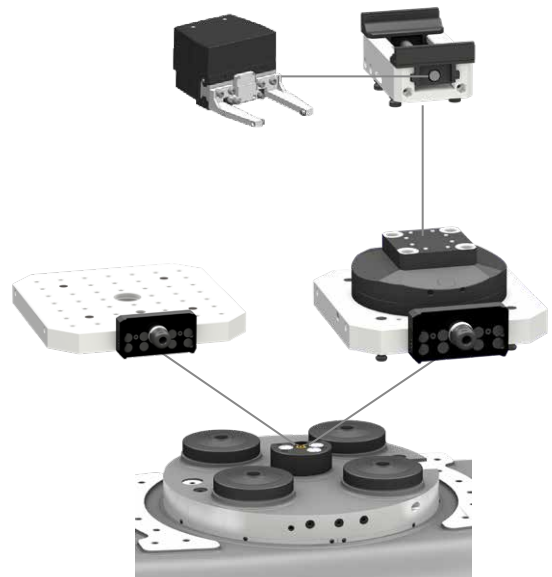

Clamping Interface 1



Maschinenfabrik  
Berthold HERMLE AG  
Industriestraße 8-12  
D-78559 Gosheim

Phone +49 (0)7426 95-0  
info@hermle.de | www.hermle.de

Subject to technical modifications. 04/25/HS flex hybrid/1000/EN/ON



The machining examples used in this leaflet are published with the explicit and kind permission of our customers. The information in this brochure only contains general descriptions and/or performance features that, in a concrete application, may not always apply in the form described or represented here or may have changed due to further development of the products. The performance features desired shall only be binding if they have been expressly agreed upon in writing at the time of the contract. The machines shown may incorporate options, accessories and control variants.